

ROHS

For reference only

Pin数	尺寸A	尺寸B	尺寸C
2x5	5.08	9.55	8.89
2x6	6.35	10.82	10.16
2x7	7.62	12.09	11.43
2x8	8.89	13.36	12.70
2x9	10.16	14.63	13.97
2x10	11.43	15.90	15.24
2x11	12.70	17.17	16.51
2x12	13.97	18.44	17.78
2x13	15.24	19.71	19.05
2x14	16.51	20.98	20.32
2x15	17.78	22.25	21.59
2x16	19.05	23.52	22.86
2x17	20.32	24.79	24.13
2x18	21.59	26.06	25.40
2x19	22.86	27.33	26.67
2x20	24.13	28.60	27.94
2x21	25.40	29.87	29.21
2x22	26.67	31.14	30.48
2x23	27.94	32.41	31.75
2x24	29.21	33.68	33.02
2x25	30.48	34.95	34.29
2x26	31.75	36.22	35.56
2x27	33.02	37.49	36.83
2x28	34.29	38.76	38.10
2x29	35.56	40.03	39.37
2x30	36.83	41.30	40.64
2x31	38.10	42.57	41.91
2x32	39.37	43.84	43.18
2x33	40.64	45.11	44.45
2x34	41.91	46.38	45.72
2x35	43.18	47.65	46.99
2x36	44.45	48.92	48.26
2x37	45.72	50.19	49.53
2x38	46.99	51.46	50.80
2x39	48.26	52.73	52.07
2x40	49.53	54.00	53.34
2x41	50.80	55.27	54.61
2x42	52.07	56.54	55.88
2x43	53.34	57.81	57.15
2x44	54.61	59.08	58.42
2x45	55.88	60.35	59.69
2x46	57.15	61.62	60.96
2x47	58.42	62.89	62.23
2x48	59.69	64.16	63.50
2x49	60.96	65.43	64.77
2x50	62.23	66.70	66.04

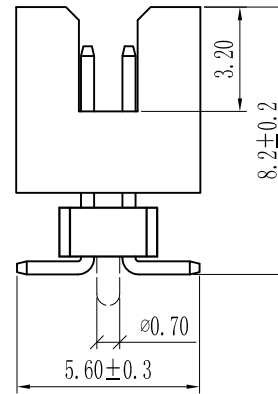
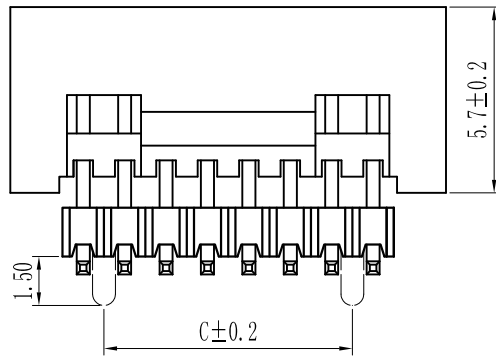
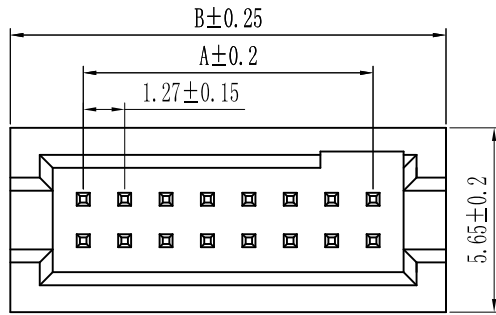

PCB LAYOUT

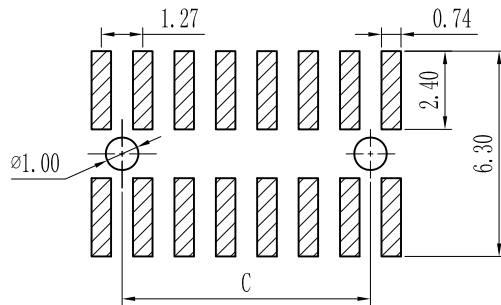

Specification:
 Current Rating : 1AMP
 Temperature Range : -40°Cto+105°C
 Contact Resistance : 20mΩ Max
 Insulation Resistance : 1000MΩ Min
 Withstanding Voltage : AC 500V
 Material:
 Insulator : Polyester (UL94V-0)
 Standard:PA6T/LCP
 Contact: Brass
 Plating : Au or Sn Over 50u" Ni

				GENERAL TOLERANCES		SCALE: 1:1	NAME	DATE	深圳市联索连接器有限公司 SHENZHEN UNICABLE CONNECTOR CO.,LTD.		PART. NO: LSBH-0010	
				L INEAR ANGLES		APPROVED			公司网址WWW.SZLSTC.CN 公司电话0755-23765650 公司邮箱SZLSTC@126.COM 公司传真0755-23765753		DWG. NO: ENDE2010	
				0.00±0.15 X° ±3°		DESIGNER			TITLE: Pitch1.27mm Box Header,Dual Row, Plastic Height 5.7mm,Elevator SMT (with Local Peg) Type		REV: AO SHEET: 1/1	
REV.	REVISION RECORD		DATE	UNIT: MM	SIZE: A4	DRAWN						